



Art-Stor[®]
Storage made easy from Richards-Wilcox



RICHARDS-WILCOX GIVES YOU THE INSIDE TRACK ON HANDLING HEAVY LOADS.

Richards-Wilcox was asked to provide safe storage for valuable, consigned patron paintings when not on public display. Our goal was to maximize storage, utilizing an existing 21' x 40' finished room.

HARDWARE CAPACITIES UP TO 5,000 LBS.

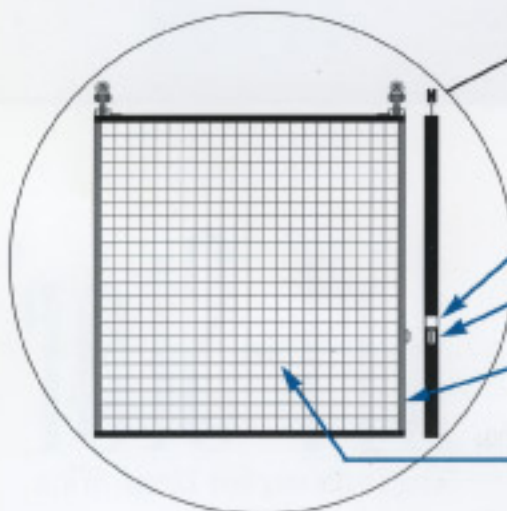
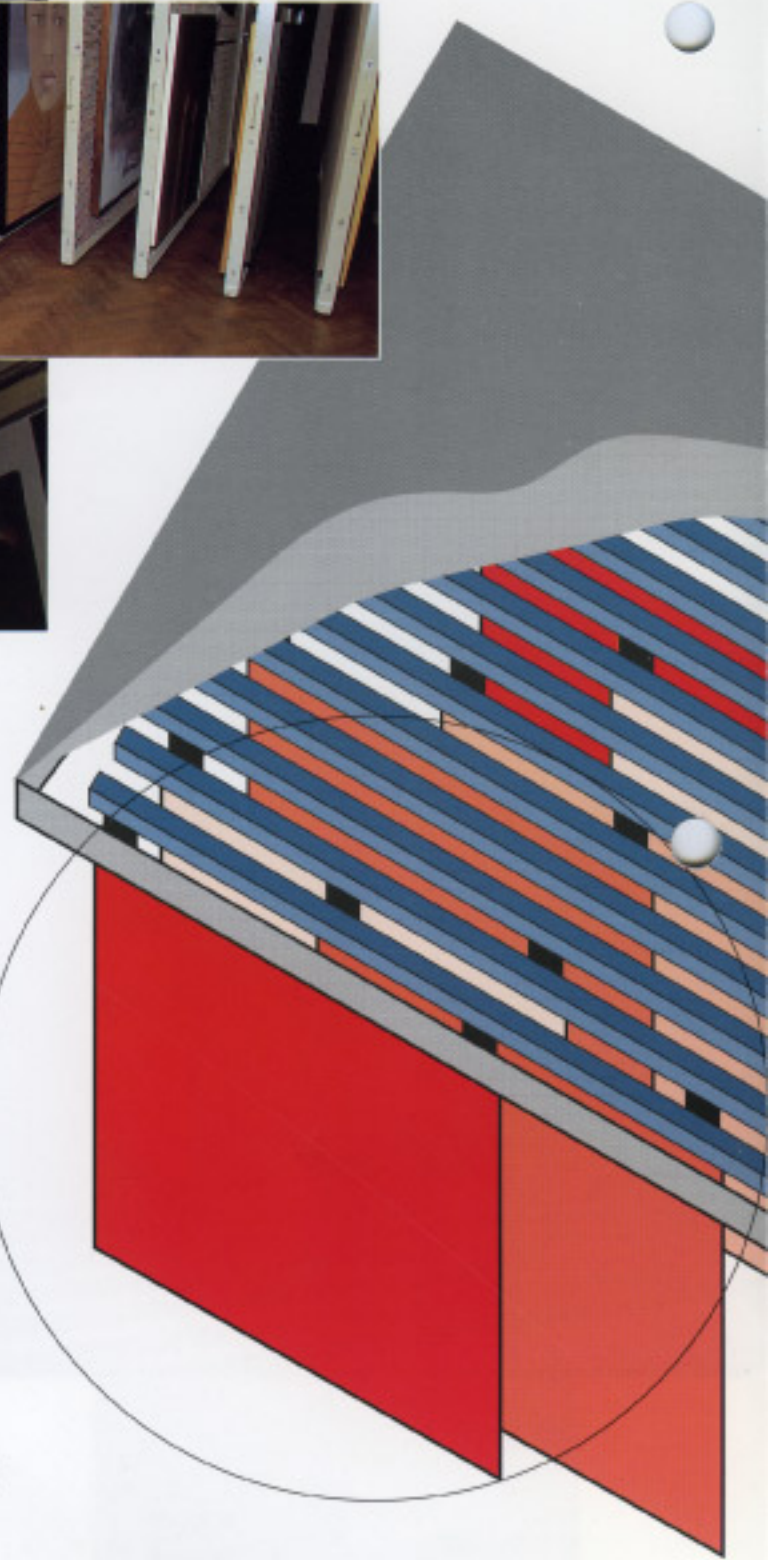

Art index card

Bow handle

Steel frame

1/8" Rigid wire welded at inter-
sections to receive standard
picture hooks

TUFF-TRACK™

3/16" thick track wall
1-3/4" W X 2-5/16" H

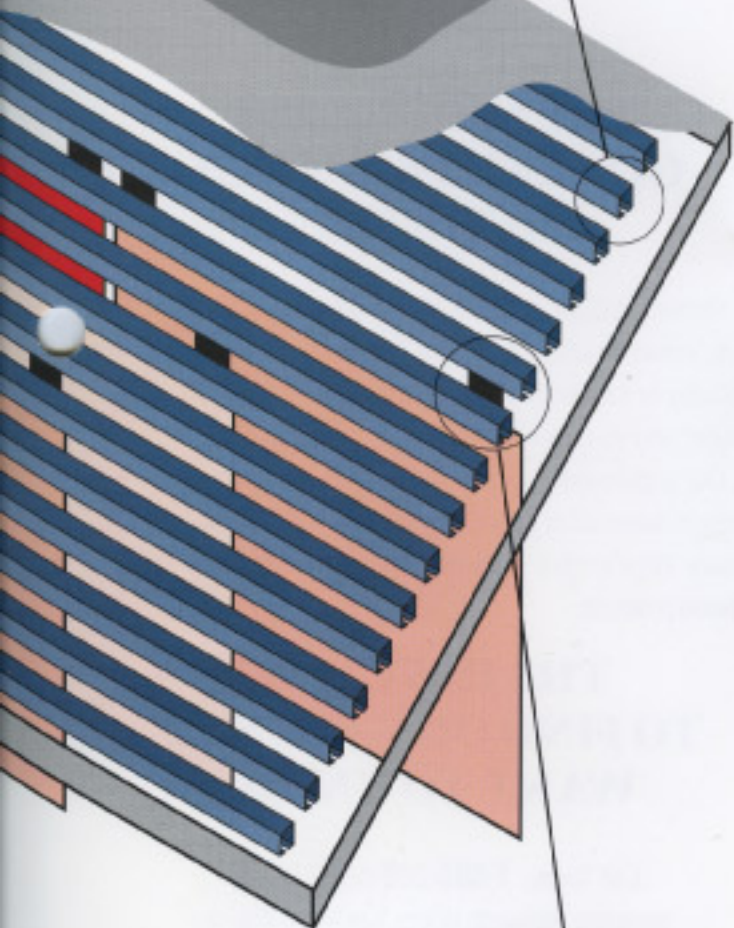
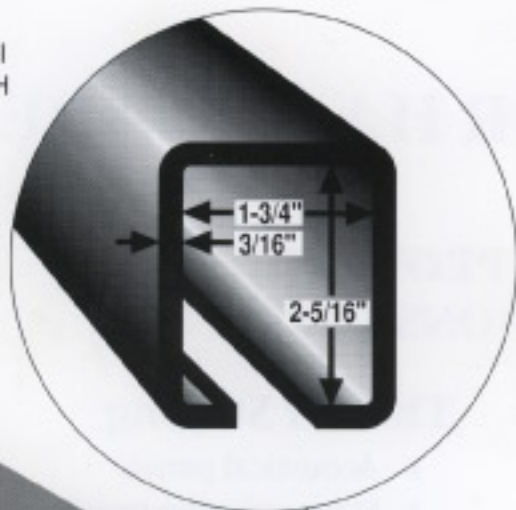

TUFF-TRACK™ CARRIERS

Two-wheel trucks with a combination of steel ball bearings and lateral thrust rollers keep a Tuff-Track™ System rolling for years. Each pair of carriers has a capacity of 600 pounds.



YEARS OF EXPERIENCE WITH STRONG CARRIERS THAT ASSURE SMOOTH OPERATION.

Richards-Wilcox provided maximum storage by utilizing eleven parallel sliding panels. The non-displayed artwork could be safely mounted to both faces of each panel. Panels were fabricated from steel tubular frames, which supported the open wire mesh hanging surfaces. Eleven 12'9" high panels (six 19'0" long, five 12'8" long) were hung from R-W Tuff-Track hardware, which were then hung from a free standing, floor-supported overhead structural framework.

No ceiling or wall support attachments were allowed. To minimize disruption of the existing wood parquet floor, "V" shaped steel bars were fastened to an 18" perpendicular header angle at each panel end. This prevented panel sway in lieu of floor mounted bottom guides.



A Tuff-Track truck was then mounted to each end of the header bar and aligned with the 18" on-center parallel track runs, forming a mini bridge crane-type carrier at either panel end. To eliminate weld or fire damage to the valuable parquet floor, mechanical fasteners were used exclusively throughout the system.

This solution provided 4,520 square feet of storage surface within only 334 square feet of floor space. A total of 120 pieces of art weighing up to 60 pounds each (7,200 total pounds) can be stored on the large panels. The smaller panels were designed to carry a total of 72 art pieces weighing up to 80 pounds each (5,760 total pounds).

Richards-Wilcox was able to utilize the strength of the 3/16" Tuff-Track steel construction positioned with 4'3" spacings, providing a cost savings over the competition's 2'0" requirements for their lighter track.

Richards-Wilcox... MORE THAN DOOR HARDWARE!

ADDITIONAL PROVEN APPLICATIONS:

Display Panels

- Art Galleries
- Museums
- Showrooms
- Boardrooms

Theater Staging

- Acoustical panels
- Stage reducing panels
- Stage curtains
- Stage light rigging

GET TO KNOW US BETTER.

Acquaint yourself with the enormous range and depth of the Richards-Wilcox product line. You'll find information on:

- Slide door hardware
- Slide-fold door hardware
- Hardware sets
- Swing door hardware
- Tuff-Track™ System
- Hardware accessories
- Capacities up to 5,000 lbs.

Richards-Wilcox offers a full-line catalog to help you select and order exactly what you need.

Our complete, 55-page Door Hardware Catalog includes detailed descriptions and specifications on hundreds of heavy-duty Richards-Wilcox products. Of course everything in it gives you legendary Richards-Wilcox strength and durability — backed by our exclusive 10-year Guarantee.

THE STRONGEST GUARANTEE IN THE BUSINESS.

Richards-Wilcox industrial-quality door hardware comes with an industrial-strength 10-year Guarantee. Compare that with the 90-day or 12-month guarantees you get from any other manufacturer, and you'll see there's simply no comparison.

Our unprecedented, unduplicated guarantee covers all defects in materials or workmanship under normal use for a full 10 years. What's more, it covers the full line of Richards-Wilcox hardware products.

THE EASY WAY TO FIND OUT ALL YOU WANT TO KNOW.

Call Today... **1-800-253-5668** for your complete Richards-Wilcox Hardware Catalog or technical assistance.



600 South Lake Street • Aurora, Illinois 60506 • 630-897-695 • Fax 630-897-6994
www.richardswilcox.com